

BUTTONS ASSEMBLY WITH ELECTRIC AXIS

- Production : 15 pcs/min
- Operators : none
- Automatic operations
 - shell loading
 - shell pressing
 - reverse loading
 - Gjpsum loading
 - Pressing of shell on reverse
 - Finished part unloading
- Different series of parts can be manipulated
- Extreme easy system management

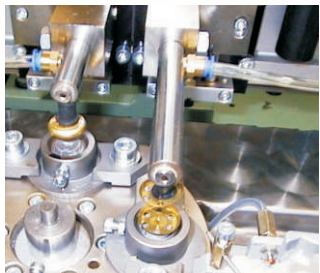

BUTTONS ASSEMBLY WITH ELECTRIC AXIS

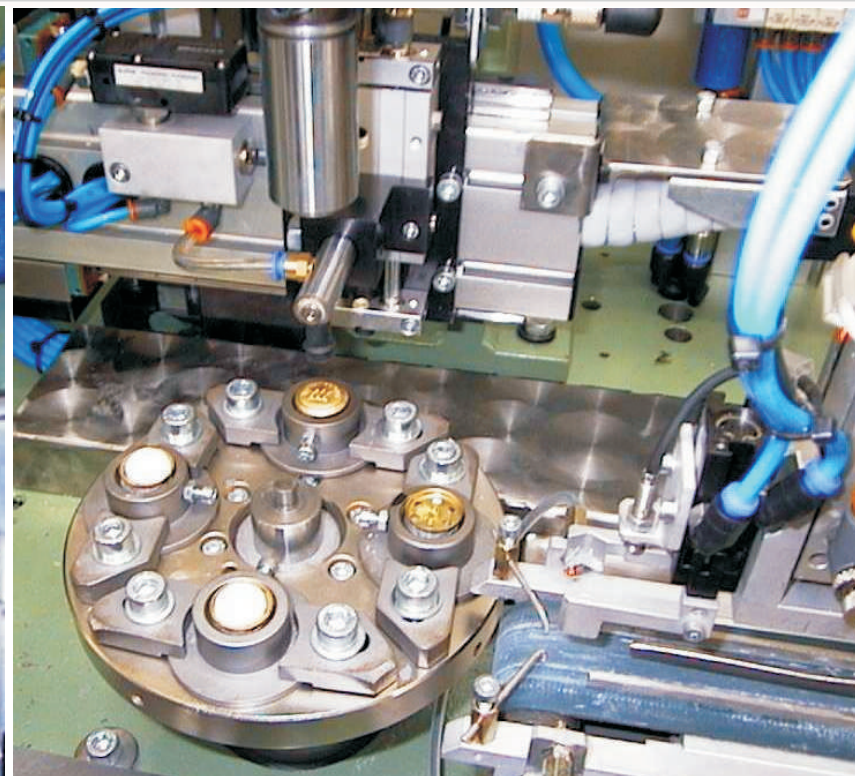
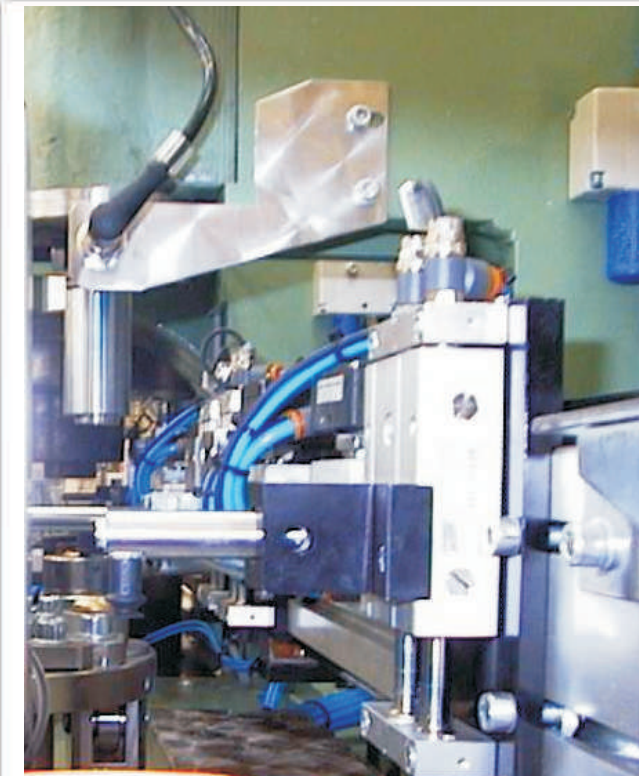
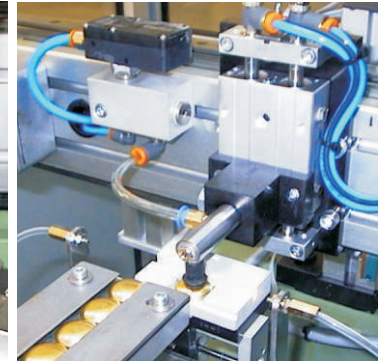
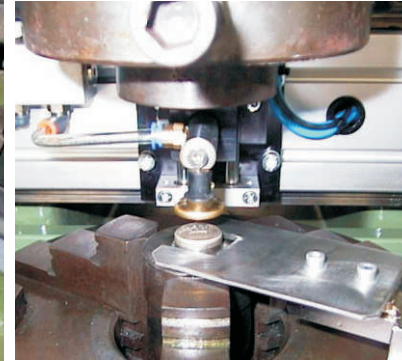
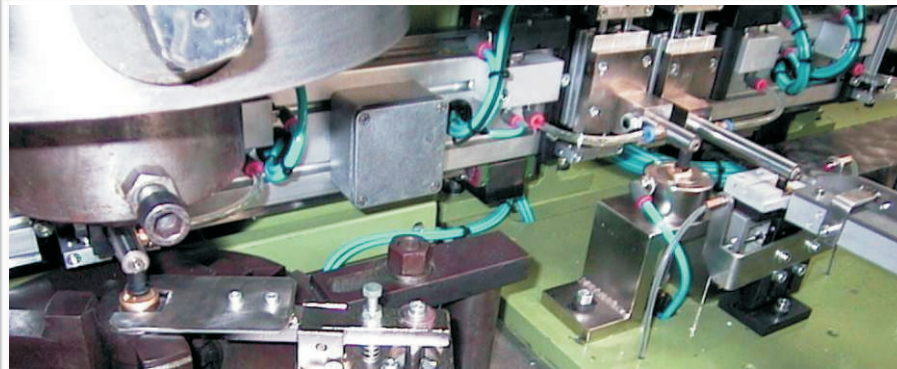
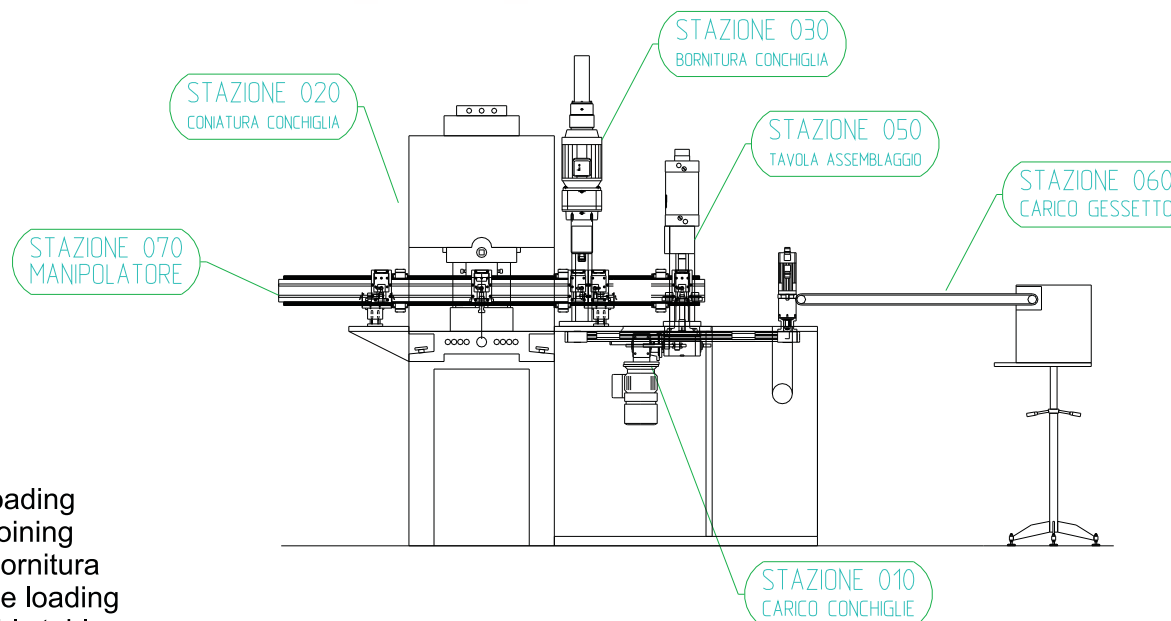

- 010 : Shell loading
- 020 : Shell coining
- 030 : Shell Bornitura
- 040 : Reverse loading
- 050 : Assembly table
- 060 : Gypsum loading
- 070 : Electric manipulator

