

ST.030
Tightening of SCREWS (x4)
of the second flange

ST.040
Automatic execution of the following tests:

- Leakage air test (low pressure)
- Leakage air test (high pressure)
- Flow test (opened valve)

ST.050
Automatic crimping for
the well tested VALVES

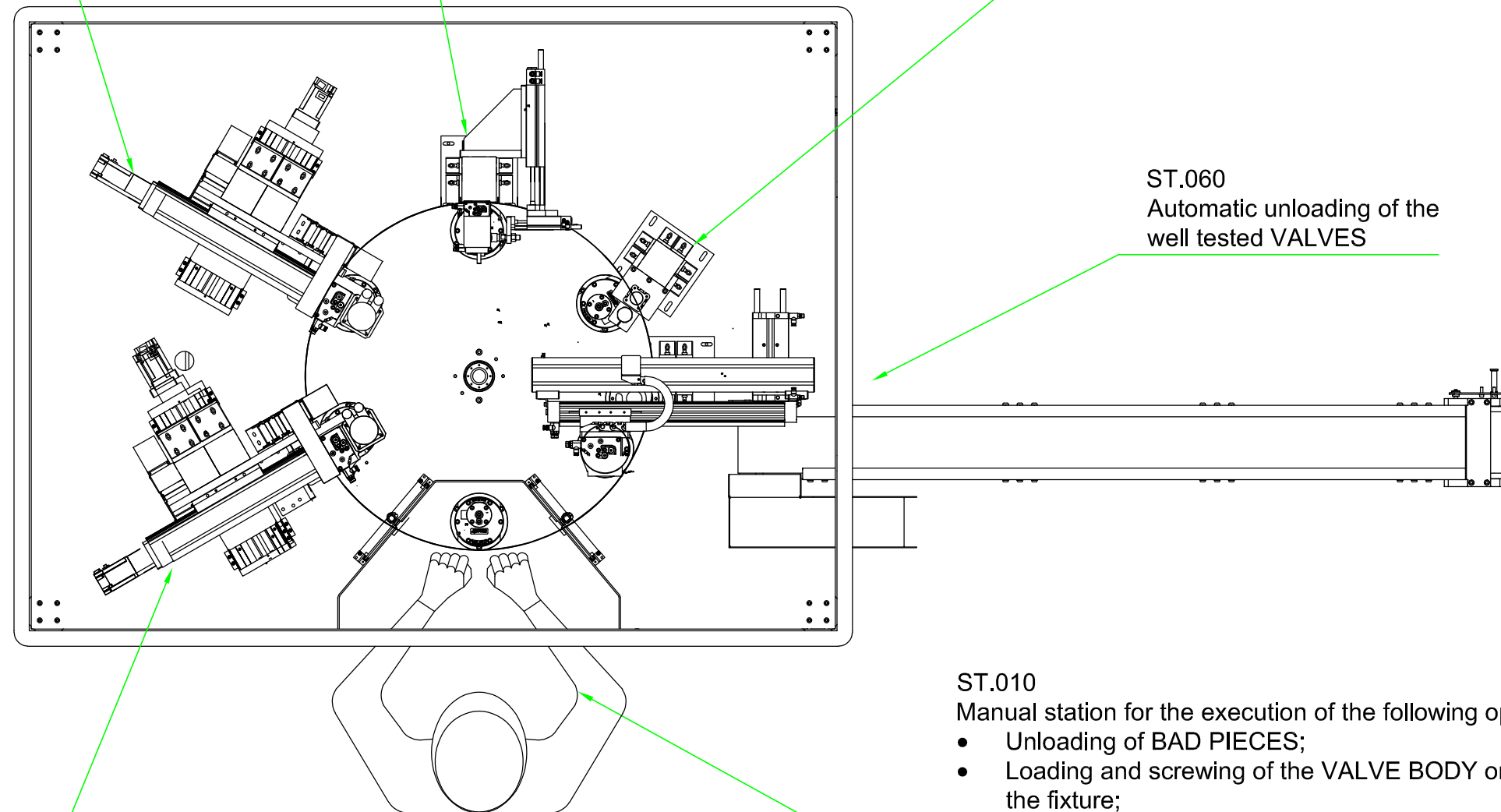

ST.060
Automatic unloading of the
well tested VALVES

ST.020
Tightening of SCREWS (x6)
of the first flange

ST.010
Manual station for the execution of the following operation:

- Unloading of BAD PIECES;
- Loading and screwing of the VALVE BODY onto the fixture;
- Pre-assembling of valve components, pre-tightening the SCREWS.

6" and 8" DIAPHRAGM VALVE ASSEMBLING and TESTING MACHINE